



# DATA SOUND - LABORATORIES - ..... EMBEDDING THE FUTURE



**Electronic  
Design**



**Panel  
PC / HMI**

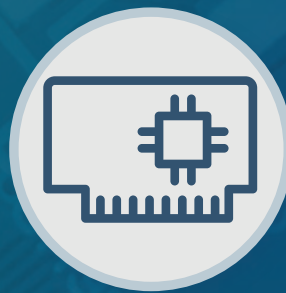

**Single Board  
Computer**



**Industrial  
PC**

## Why choose DSL?

- Over 25 Years Industry Experience
- 5 Years Warranty on all Products
- Evaluation Products Available
- Lifetime Technical Support

## Our Services

- Electronic Design
- Production Management
- Assembly and Test
- Bespoke BIOS Creation
- Industrial Embedded PC Solutions



Call us on +44(0)1462 675530



Email us at [sales@dsl-ltd.co.uk](mailto:sales@dsl-ltd.co.uk)



[www.dsl-ltd.co.uk](http://www.dsl-ltd.co.uk)

# EBOX Apollo Lake Series

Fanless PC with Intel® Apollo Lake N3350 Dual core and J3455 Quad core processor.

Support memory up to 8GB DDR3L, Multi-Display outputs, Multi-COM functions, Dual Giga LAN etc.

Perfect platform for IoT, M2M, Industry 4.0, Home Automation, Security, Public transportation and many other more.

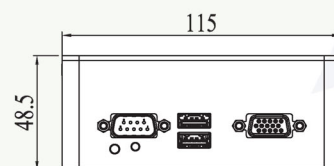
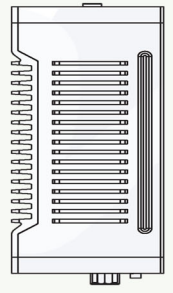
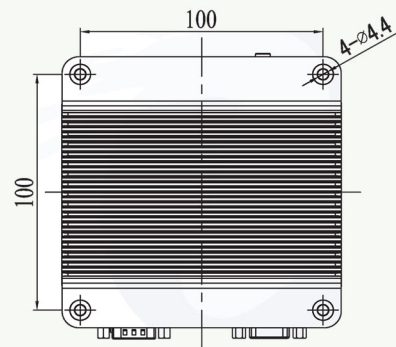
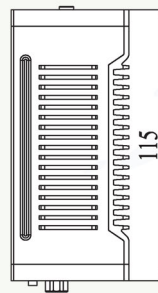
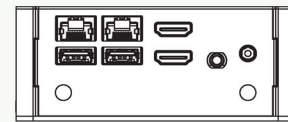

## Features

- Intel® Apollo Lake N3350 Dual Core 1.10GHz
- Intel® Apollo Lake J3455 Quad Core 1.50GHz
- Multi-Display, Multi-COM functions support
- Fanless, 100x100mm VESA support
- Full-size, Half-size mPCIe slot support
- Auto Power On support

# EBOX-ALN3350/ EBOX-ALJ3455

## System Specifications

Processor	Intel® Apollo Lake N3350 Dual Core 1.10GHz, 2.40GHz (Burst) 6W Intel® Apollo Lake J3455 Quad Core 1.50GHz, 2.30GHz (Burst) 10W	
Memory	SO-DIMM slot x1, DDR3L-1866MHz up to 8GB	
BIOS	AMI UEFI BIOS	
Expansion	Full-size MiniPCle x1 (co-lay mSATA for Storage) Half-size MiniPCle x1 SIM card slot (Function via Full-size MiniPCle)	
Display	Intel® HD Graphics with Multi-Display support HDMI : Maximum resolution support up to 3840 x 2160 @30Hz VGA: Maximum resolution support up to 1920 x 1200 @60Hz	
HD Audio	Realtek ALC662VD Mic-in + Line-out	
Ethernet	Realtek 8111H GigaLAN x2 (Built-in PXE diskless boot)	
Disk Support	mSATA x1	SATA device x1
Internal I/O	4-pin wafer for SATA power output x1 5-pin header for SMBus x1 USB 2.0 x2 (pin type)	SIM card holder x1 Full-size MiniPCle slot / mSATA x1 Half-size MiniPCle slot x1
External I/O	HDMI V1.4 x2 15-pin D-sub connector for VGA x1 9-pin D-sub connector for COM x1 (RS-232/485/422)	USB 3.0 x4 RJ45 connector for GigaLAN x2 Phone Jack for Line-out / MIC-in x1
Power Requirement	DC +12V standard input from power jack	
Operating Temperature	0°C~ 60°C (with Airflow)/ -10°C Bootable	
Dimension	115 x 115 x 48.5mm	
Mounting	VESA 100 x 100mm	
Net Weight	660g	
Certifications	CE, FCC, VCCI	
OS Support	Windows 10, Windows 10 IoT, Linux	